



GLOWBAL

HVAC-R

Product Catalogue

Panasonic



Rinnai



GreenEarth



BLUEDIAMOND[®]
CONDENSATE REMOVAL PUMPS

Glowbal NZ Limited
11 Pavilion Dr, Airport Oaks, Auckland, New Zealand
sales@glowbal.co.nz | +64 9 254 4500

TABLE OF CONTENTS

	Page #
Heat Pumps & Accessories	2-6
Chemicals	7
Temperature Controllers	8
Axial Fans & Motors	9-11
Refrigerants, Cylinders & Accessories	12-16
Pair Coils	17
Ducting & Accessories	18
Base Mounts	19-20
Roof Mounts	20
Wall Brackets	21



CS/CU-Z25XKR-1
2.5kW

CS/CU-Z35XKR
3.5kW

CS/CU-Z20XKR
2.05kW

CS/CU-Z42XKR
4.2kW

CS/CU-Z50XKR
5.0kW

PANASONIC HIGH WALL R32 HEAT PUMPS



Panasonic AERO SERIES

NANOE X TECHNOLOGY • WIFI &
WIRED • BLUE FIN CONDENSER



CS/CU-Z50XKR-1
5.0kW

CS/CU-Z60XKR-1
6.0kW

CS/CU-Z71XKR
7.10kW

CS/CU-Z80XKR
8.0kW



HSNRP26

2.5 KW Cool / 2.7 KW Heat



HSNRP35

3.5 KW Cool / 4.0 KW Heat



HSNRP50

5 KW Cool / 5.2 KW Heat

**RINNAI HIGH WALL
HEAT PUMPS**

Rinnai PRO SERIES

PRO-PEL COIL PROTECTION • 3D AIRFLOW
TRIPLE HEALTH FILTER • WIFI CONTROL



HSNRP60

6.0 KW Cool / 6.2 KW Heat



HSNRP70

7.0 KW Cool / 7.5 KW Heat



HSNRP80

8.0 KW Cool / 8.5 KW Heat

**AIR CONDITIONING**

Single Split Systems

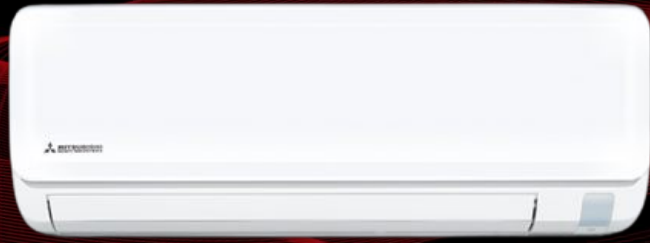
**Wall Mounted****Ciara™ Series****POWER:** Single Phase | **AVAILABLE IN:** Reverse Cycle**CAPACITIES:** 1.5kW | 2.0kW | 2.5kW | 3.3kW | 5.0kW | 6.3kW | 7.1kW**Key Features**

- ✓ BUILT-IN WI-FI AND VOICE CONTROL COMPATIBILITY (VIA GOOGLE & ALEXA DEVICES)
- ✓ COMPACT YET ELEGANT DESIGN
- ✓ CLEAN AIR TECHNOLOGY TO CAPTURE AND NEUTRALISE ALLERGENS, ODOURS, BACTERIA & VIRUSES
- ✓ QUIET OPERATION WITH TWO LEVELS OF SILENT MODE ON OUTDOOR UNIT
- ✓ INTUITIVE REMOTE CONTROL WITH BACKLIT DISPLAY



SRC20-35ZSA-W



SRC-50ZSA-W

AIR CONDITIONING

Single Split Systems

Wall Mounted

Avanti® Series

Recommended by Consumer, the Avanti® split system heat pump combines sleek, stylish design with advanced functionality. It features Clean Air Technology, which helps to improve indoor air quality by capturing and neutralizing allergens, odours, bacteria, and viruses. Ideal for small to medium spaces, the Avanti® split system heat pump offers a blend of elegance and convenience.

POWER: Single Phase | **AVAILABLE IN:** Reverse Cycle

CAPACITIES: 2.0kW | 2.5kW | 3.5kW | 5.0kW

Key Features

- ✓ MODERN AND STYLISH DESIGN
- ✓ 3D AUTO AIRFLOW FOR EFFECTIVE AND EVEN AIR DISTRIBUTION
- ✓ CLEAN AIR TECHNOLOGY TO CAPTURE AND NEUTRALISE ALLERGENS, ODOURS, BACTERIA & VIRUSES
- ✓ WIDE RANGE OF TIMER AND SCHEDULING FUNCTIONS
- ✓ LED BRIGHTNESS CONTROL



SRK20-50ZSA-W



SRC20-35ZSA-W



SRC50ZSA-W

Single Split Systems



Wall Mounted

Bronte® Series

Recommended by Consumer, the Bronte® split system heat pump incorporates advanced fan blade technology to efficiently deliver an industry leading, long reach airflow of 18m+ making it perfect for larger spaces. It also incorporates 3D Auto Mode, various timers and Clean Air Technology which helps to improve indoor air quality by capturing and neutralizing allergens, odours, bacteria and viruses as well as inhibiting the growth of mold.

POWER: Single Phase | **AVAILABLE IN:** Reverse Cycle

CAPACITIES: 6.3kW | 7.1kW | 8.0kW | 9.5kW | 10.0kW

Key Features

- ✓ JET AIR TECHNOLOGY DELIVERING INDUSTRY LEADING LONG REACH AIRFLOW
- ✓ CLEAN AIR TECHNOLOGY TO CAPTURE AND NEUTRALISE ALLERGENS, ODOURS, BACTERIA & VIRUSES
- ✓ WIDE RANGE OF CONVENIENT TIMER AND SCHEDULING FUNCTIONS
- ✓ PRODUCTREVIEW'S BEST SPLIT SYSTEM THREE YEARS RUNNING
- ✓ OPTIONAL WI-FI CONTROL WITH WI-FI ADAPTOR



SRC63ZRA-W



SRC71-80ZRA-W



SRC95ZRA-W



FDCA100VNA-W



DSNR07B1

7.3 KW Cool / 7.5 KW Heat
Mid static - slim ducted



DSNR09B1

9.0 KW Cool / 10.0 KW Heat
Mid static - slim ducted

**RINNAI PRO SERIES
DUCTED HEAT PUMPS**



Rinnai 7.5 - 18KW RANGE

PRO-PEL COIL PROTECTION • WIFI CONTROL
ECO COOL • DAILY & WEEKLY TIMER • ZONING

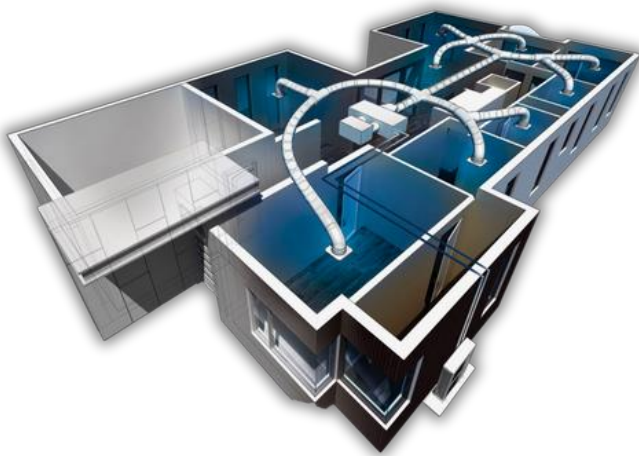

DSNR11B1

10.5 KW Cool / 11.5 KW Heat
High static - ducted

DSNR13B1

12.5 KW Cool / 13.0 KW Heat
High static - ducted

DSNR15B1

14.0 KW Cool / 14.5 KW Heat
High static - ducted

DSNR18B1

17.0 KW Cool / 18.0 KW Heat
High static - ducted



AIR COOLED EUROVENT & AHRI CERTIFIED CHILLERS

Clivet Eurovent Certified Air Cooled Chillers range from Twin Section Liquid Chillers available with Inverter Screw Compressors and Multi Stage Scroll Compressors with R1234ze, R32, R410a and R513a refrigerant



CLIVET MULTI FUNCTION CHILLERS

Clivet Eurovent 4 Pipe Multi-Function Chillers provide absolute flexibility for a client's needs in providing concurrent cooling and heating solutions. Clivet offer a full range of Multi-Function Chillers with onboard pumps, buffer tanks and the highest specification coil protection

AIR COOLED LIQUID CHILLERS

Air Cooled liquid chillers and heat pumps scroll inverter technology for commercial and industrial installations with Low Environmental Impact Solution R32 refrigerant.

- Cooling Only, 43-98kW range
- Reversible heat pump, 22-55kW range
- High Seasonal efficiencies
- Low GWP
- Silenced with sound levels reduced by -8 dB
- Super-silenced with sound levels reduced by -10dB





ROOF TOP PACKAGE UNITS

We provide customers with the largest range of DX and Roof Top Packaged systems available globally. Our range in capacities allows us to explore all your HVAC needs and to deliver both a technical and energy efficient solution.

HEAT RECOVERY & FULL FRESH AIR DX PACKAGE UNITS

Clivet provides the largest range of heat recovery and full fresh air package units available globally. Our large range allows us to deliver an unrivalled technical and energy efficient solution. Our Full Fresh Units Provide flexible options and configurations



AHU

Premium spec Air Handling Units for high profile projects and/or high humidity applications in modular design, they have the flexibility to add components as required. MAHU use unitary structure design that have more outstanding cold – bridge – free performance, lower air leakage and a more elegant appearance.

- TB1($0.75 \leq k < 1.00$) thermal bridging class, And T2($0.5 < U \leq 1$) thermal transmittance class.
- Eurovent certified
- Certified testing to EN 1886



R-CDD/1 • R-CDD/5

GreenEarth Coil Disinfectant
 EPA Registered
 Hospital Grade
 1 Litre sprayer, 5 Litre bottle

R-ECC/1 • R-ECC/5

**GreenEarth Evaporator
 Coil Cleaner**
 Also available in 20 Litres:
 R-ECC/20

R-FCC/1 • R-FCC/5

**GreenEarth Foam-Brite
 Alkaline Condenser Cleaner**
 Also available in 20 Litres:
 R-FCC/20

CHEMICALS

GreenEarth 

**HVAC-R CLEANING &
 MAINTENANCE**

R-FCD/1

GreenEarth Air Filter Cleaner
 Biodegradable
 1.0 Litre c/w sprayer

R-FCD/5

GreenEarth Air Filter Cleaner
 Biodegradable
 5.0 Litre bottle

4182-24

Cal-Blue Micro Leak Detector
 Freeze Protective & non-Corrosive
 0.95 Litre c/w sprayer

XR20CX-B

Medium Temp Controller
with "off cycle" defrost.
1 x NTC

XR30CX-B

Medium Temp Controller with
"off cycle" defrost and additional
configurable relay.
1 x NTC

DIXELL® TEMPERATURE CONTROLLERS

dixell CX SERIES

PANEL MOUNT • DUAL HUMIDITY
FUNCTION • 230V AC

XR40CX-B

Low Temp Controller with
electric defrost management.
2 x NTC

XR60CX-B

Low Temp Controller with
electric defrost, fan relay, Digi
Input.
2 x NTC

XR70CX-B

Low Temp Controller with
electric defrost, fan relay,
Auxiliary alarm relay, Digi Input.
2 x NTC



HIDRIA AXIAL FANS

Hidria**220-240V/50HZ**

SPECS

- DIAMETER: 300MM / 350MM
- 5 BLADE
- NOM. WATTS (HS / LS): 80 / 145
- SPEED RPM: 1370 / 1400
- 3.5 / 6.0 KG WEIGHT

PRODUCT CODES:

09R-3028A-4M-3509 [300MM]**R11R-3530A-4M-3852 [350MM]**

S4E300AS72CT-001

Condenser/Evaporator Fan
300mm 4P, 1PH AC fan
with basket guard

S4E350AN02CT-060

Condenser/Evaporator Fan
350mm 4P, 1PH AC fan
with basket guard

S4E400AP0244-CT0

Condenser/Evaporator Fan
400mm 4P, 1PH AC fan
with basket guard

S4E450AU0337-CT0

Condenser/Evaporator Fan
450mm 4P, 1PH AC fan
with basket guard

EBM AXIAL FANS



- LOW NOISE LEVEL
- 4P & 1PH AC
- WITH BASKET GUARD

S4E500AM0301-CT0

Condenser/Evaporator Fan
500mm 4P, 1PH AC fan
with basket guard

S6E560AN0101

Condenser/Evaporator Fan
560mm 4P, 1PH AC fan
with basket guard

S6E630AN0101

Condenser/Evaporator Fan
630mm 4P, 1PH AC fan
with basket guard

M4Q045BD0138-CT0

EBM Q Series
refrigeration fan motor
5 Watt

M4Q045CA0138-CT0

EBM Q Series
refrigeration fan motor
7 Watt

M4Q045CA0338A01-CT0

EBM Q Series
refrigeration fan motor
10 Watt

M4Q045CF0138-CT0

EBM Q Series
refrigeration fan motor
16 Watt

EBM Q SERIES FAN MOTORS



- SHADED POLE MOTOR
- DROP IN REPLACEMENT
- REFRIGERATION COMPATIBLE

M4Q045DA0538-CT0

EBM Q Series
refrigeration fan motor
23 Watt

M4Q045EA0138-CT0

EBM Q Series
refrigeration fan motor
25 Watt

M4Q045EF0138-CT0

EBM Q Series
refrigeration fan motor
34 Watt

HI-PRESSURE NITROGEN PISTON REGULATOR

 **GLOWBAL VICTOR STYLE**

SPECS

- T SCREW ADJUSTMENT & SIDE ENTRY
- EXTERNAL SAFETY RELIEF VALVE
- FORGED BRASS BODY & BONNET
- SINTERED METAL INLET FILTER
- NO SOLDERED JOINTS
- NET WEIGHT 1.5KG/EA
- SINGLE STAGE

PRODUCT CODE: DW-P4-203-50M



R134A-13.6



R410A-11.3



R407C-11.3



R404A-10.9



R407F-11.3

REFRIGERANT GAS CYLINDERS



- FOR HVAC-R EQUIPMENT
- VARIOUS APPLICATIONS



R507-11.3



R449A-11.35



R32-3.0



R600A-3.0



R290-5.0



ADAPTER VALVE

R449A / XP40 REFRIGERANT GAS



SPECS

- 11.35 KG NET WEIGHT
 - SUITABLE REPLACEMENT FOR R404A
 - DISPOSABLE CLYINDER
- PRODUCT CODE: R449A-11.35**



R454B/ XL41 REFRIGERANT GAS



SPECS

- 9.5 KG NET WEIGHT
 - SUITABLE REPLACEMENT FOR R410A
 - DISPOSABLE CLYINDER
- PRODUCT CODE: R454B-9.5**



R452A / XP44 REFRIGERANT GAS



SPECS

- 11.35KG NET WEIGHT
 - SUITABLE REPLACEMENT FOR R404A
 - DISPOSABLE CLYINDER
- PRODUCT CODE: R452A-11.35**



REFRIGERANT GAS RECOVERY CYLINDERS

 **GLOWBAL** **DOT APPROVED**



SPECS

- 21.6/41.9 LITRE BOTTLES [20 & 40KG]
 - Y-VALVE FOR LIQUID/VAPOR
 - 3/4" NPT OPENING ACCEPTS 80%
- PRODUCT CODES: RRC-21.6L / RRC-41.9L**

MAPP GAS CYLINDER

 **GLOWBAL**



SPECS

- PROPLYENE
- SUITABLE FOR BRAZING TORCH
- 400GM

PRODUCT CODE: MAPP

DISPOSABLE OXYGEN CYLINDER



SPECS

- FOR HEAVY DUTY, HI-TEMP USAGE
- SUITABLE FOR BROMIC KIT
- 136GM

PRODUCT CODE: OXY

SILVER BRAZING ROD

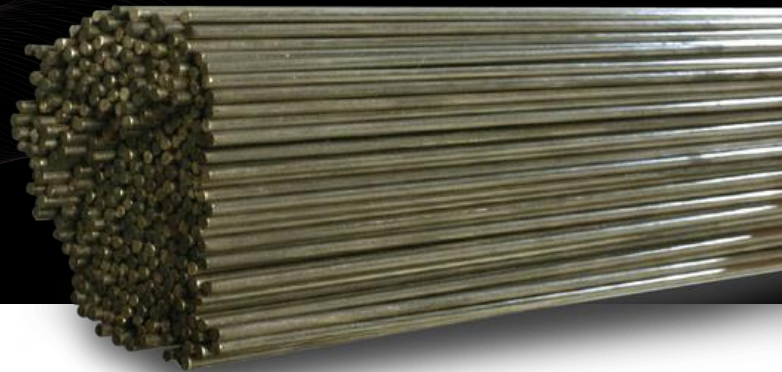

SPECS

- 2.4MM DIAMETER X 750MM LONG
- 15% SILVER
- BROWN TIP

PRODUCT CODE: P15-1KG



AP-23

Copper Pipe Thickness:
1/4" x 3/8"
Tube Wall Thickness:
0.8 x 0.8mm



AP-24

Copper Pipe Thickness:
1/4" x 1/2"
Tube Wall Thickness:
0.8 x 0.8mm



PAIR COILS



Fire Rated
to EU Stds



Pre-Insulated
Copper 20M



R410A
Compliant



AS/NZS 1571
Compliant



AP-25

Copper Pipe Thickness
1/4" x 5/8"
Tube Wall Thickness:
0.8 x 1.0mm



AP-35

Copper Pipe Thickness
3/8" x 5/8"
Tube Wall Thickness:
0.8 x 1.0mm



AP-36

Copper Pipe Thickness
3/8" x 3/4"
Tube Wall Thickness:
0.8 x 1.2mm

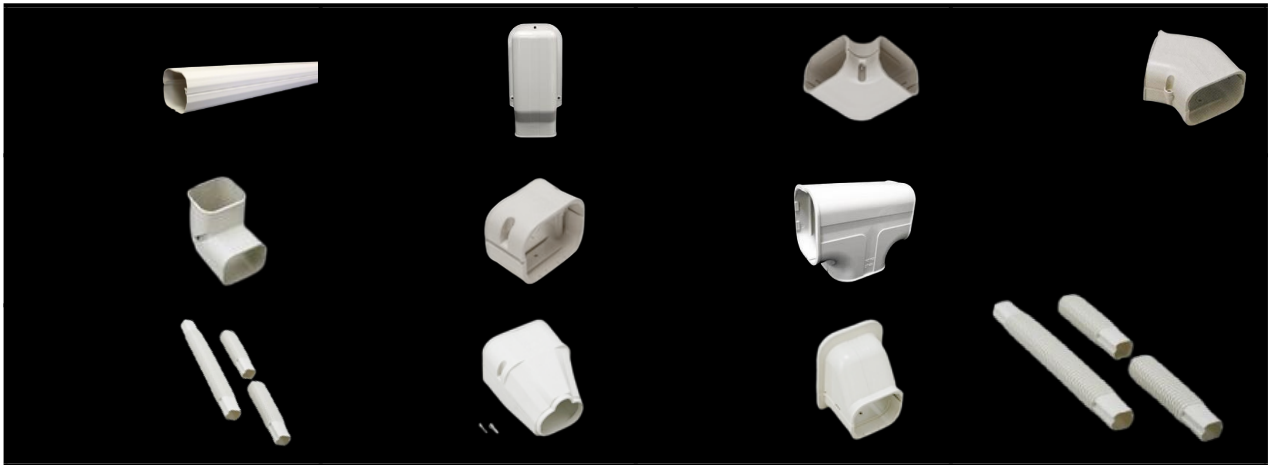

& HVAC FITTINGS

DUCTING



-  Hi-Grade PVC
-  UV Ray Rated
-  Weather Resistant
-  Easy Install For split units

120MM DUCTING

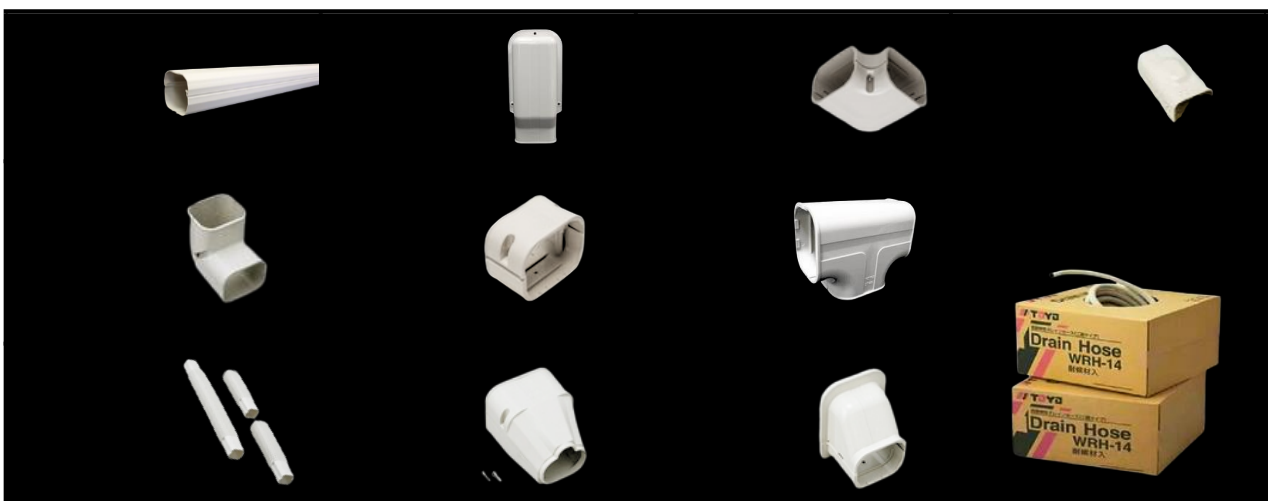

POLYSLAB HVAC-R BASE MOUNTING

POLYSLAB UV RESISTANT

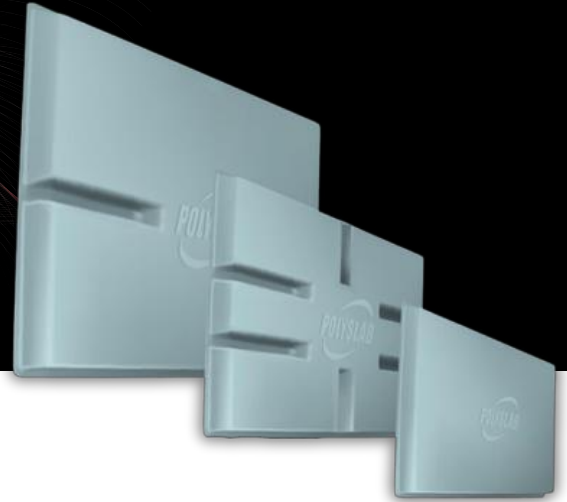

SPECS

- DIAMETER 465 X 885 X 51MM [MEDIUM]
- 160KG LOAD RATING
- ALSO AVAILABLE IN SMALL / LARGE

PRODUCT CODES:
PS465 [MEDIUM]

PVC FLOOR SUPPORT

 **GLOWBAL**



SPECS

- DIAMETER 450MM
- WITH STAINLESS STEEL NUTS & BOLTS

PRODUCT CODES:
FSP2

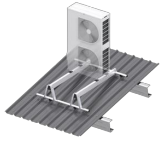
CS001.12.3

Light Weight Single Mount
300mm Adjustable Support
1200mm Purlins
0-80KGS

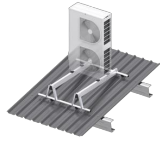
CS001.15.6

Light Weight Single Mount
600mm Adjustable Support
1500mm Purlins
0-80KGS

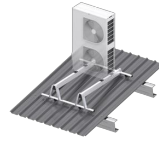
CS001.18.6

Light Weight Single Mount
600mm Adjustable Support
1800mm Purlins
0-80KGS

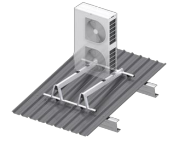

CS001H.12.3

Heavy Duty Single Mount
300mm Adjustable Support
1200mm Purlins
80-150KGS

CONDENSER MOUNTS & BRACKETS

Monkeytee

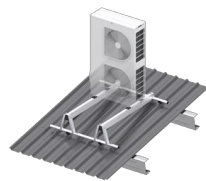
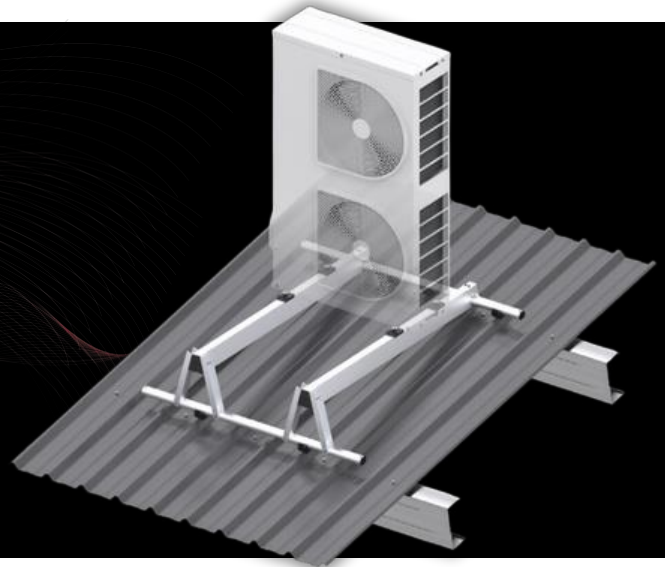
- ROOF MOUNTS & WALL BRACKETS
- ADJUSTABLE ALUMINIUM
- LIGHT & HEAVY WEIGHT

CS001H.15.6

Heavy Duty Single Mount
600mm Adjustable Support
1500mm Purlins
80-150KGS

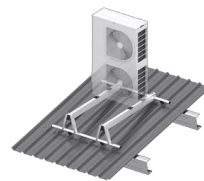
CS001H.18.6

Heavy Duty Single Mount
600mm Adjustable Support
1800mm Purlins
80-150KGS

WALL BRACKETS FOR A/C UNITS

 **GLOWBAL TWO SIZES**

SPECS

- FOR A/C CONDENSORS
- GALV & POWDER COATED
- MAX WEIGHT 100KG / 150KG

**PRODUCT CODES:
HL-450 / HL-550**